

Growing Kiwifruit



Contents

Bernadine Strik, Extension berry crops professor, Department of Horticulture, Oregon State University.

The technical assistance of Helen Cahn and Gil Buller, North Willamette Research and Extension Center, and Chantalak Tiyyon and Marieles Pescie, graduate students, Oregon State University, is appreciated.

Introduction	1
Kiwifruit Cultivars	
“Fuzzy” Kiwifruit	3
Hardy Kiwi	4
Kolomikta Kiwi	6
Establishing Your Kiwifruit Vineyard	
Site Selection and Preparation	7
Vineyard Planning, Planting, and Spacing	8
Trellis	10
Irrigation	11
Fertilization	12
Training Young Vines	13
Maintaining Your Kiwifruit Vineyard	
Fertilization	16
Irrigation	17
Pollination	17
Fruit Thinning	18
Pruning and Training	18
Harvest, Handling, and Storage of Kiwifruit	
Fruit Maturation	21
Harvesting	22
Storage	22
Pests	23

Introduction

Kiwifruit are native to southeast Asia. There are more than 50 species in the genus *Actinidia*, and many have commercial potential.

The most common kiwifruit species grown commercially is *Actinidia deliciosa* cultivar Hayward. Consumers are very familiar with this brown, fuzzy fruit.

Hayward needs a growing season of about 225 to 240 frost-free days. Although this species should tolerate temperatures down to 10°F (−12°C), plants may be damaged at slightly higher temperatures.

Actinidia chinensis, another large-fruited species, is grown commercially to a limited extent; this species offers yellow-fleshed cultivars. However, *A. chinensis* is not quite cold-hardy enough for consistent production in the Pacific Northwest.

More hardy kiwifruit species also are available. They include the following:

- *A. arguta*, known as the hardy kiwi or arguta (marketed as “baby kiwi” and “wee-kis” in Oregon and as “grape kiwi” in British Columbia)

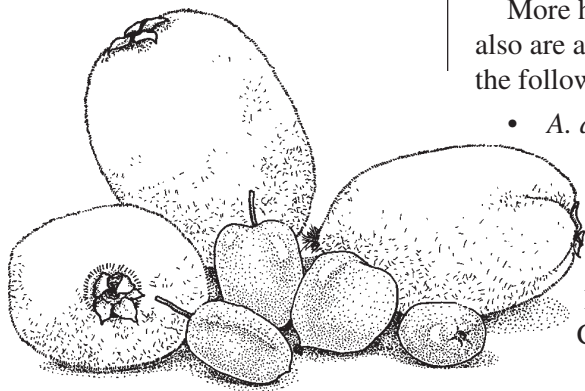

- *A. kolomikta*, also known as kolomikta or Arctic Beauty, which is cold hardy to −40°F (−40°C)

Young shoots and fruit of *all* kiwifruit species are very sensitive to frost injury. Temperatures of 30°F or less (−1°C) for only 30 minutes can severely damage shoots in the spring and fruit in the fall. Thus, in frost-sensitive areas, kiwifruit can be grown successfully only with overhead irrigation for frost protection (see “Irrigation”) or by using some other frost protection method (see “Site Selection”).

The kiwifruit is a dioecious plant—it has separate male and female plants (with the exception of a few self-fertile cultivars). It is essential to plant male vines for pollination and crop production.

It is best to plant male and female vines of the same species. In general, 1 male is required for every 6 to 10 females. Self-fertile cultivars require no male pollinizer, although fruit size may be larger with cross-pollination.

The fruit of most common kiwifruit species and cultivars have green flesh that does not brown when cut. Some commercial cultivars have yellow or red flesh.

Although some people claim they eat the skin of fuzzy kiwi,

most peel these fruit. However, the hardy and kolomikta kiwifruit have very edible skin. You can pop these delicious, small fruits right into your mouth.

Kiwifruit are relatively high in acid, with the acid content reaching nearly 2 percent of fresh weight at maturity and declining after harvest. Kiwifruit are one of the best natural sources of vitamin C, with a level at least twice that of the orange.

Fuzzy kiwifruit can be stored for months after harvest at 32 to 35.5°F (0 to 2°C). However, the hardy kiwis can be stored for no more than 2 months under the same storage conditions. Therefore, you likely will see hardy kiwifruit in stores up to only a couple of months after harvest (September through October) unless fruit are produced in the southern hemisphere and are shipped here.

Leaves of some kiwifruit species (*A. kolomikta* and *A. polygama*) contain a substance that has an effect similar to catnip. In China, kiwivine leaves reportedly are fed to large cats as a sedative. You may find that cats become a pest of your new kiwifruit planting! *A. polygama* makes a nice ornamental vine. The fruits are considered of lower quality than those of other hardy species.

Kiwifruit Cultivars

The information below on ripening dates, fruit weights, and plant performance is approximate and is for mature vines. It is based on test results from a cultivar planting at the Oregon State University North Willamette Research and Extension Center (NWREC), Aurora, Oregon. Performance may vary with location.

“Fuzzy” Kiwifruit

Actinidia deliciosa, fuzzy kiwifruit, is the most widely available species. Fuzzy kiwi are grown commercially in New Zealand, Italy, Japan, France, Australia, Greece, Chile, and California. There is some commercial production in

Oregon and Washington (United States) and in British Columbia (Canada); however, this species is not extremely hardy and may suffer cold injury in some years in the Pacific Northwest.

Cold damage usually occurs when temperatures drop during the night after a warm spell, particularly when vines are not fully dormant (in

fall or late winter). The trunk usually is damaged, which weakens older plants and sometimes kills young vines. Although methods such as wraps and plastic sleeves may help protect the trunk against freeze injury, they are not always effective. The trunk’s sensitivity to cold decreases with age.

Generally, fruit are large, with a green skin covered with brown fuzz. Vitamin C content ranges from 100 to 200 mg per 100 grams of fruit. The most common commercial cultivar is Hayward, which is found in supermarkets throughout the world.

A yellow-fleshed fuzzy kiwifruit is now available in stores. This cultivar from New Zealand is HORT16A and is trademarked as Zespri Gold. This cultivar belongs to the species *A. chinensis*. No plants of this cultivar are presently available.

The following cultivars are available (all *A. deliciosa*) and have been tested in the Pacific Northwest. All produce bright green-fleshed fruit. Ripening dates given below are based on when fruit reached 6.5 °Brix (percent sugar) at the NWREC, a harvest date criterion for long-term storage (see “Harvest, Handling, and Storage of Kiwifruit”).

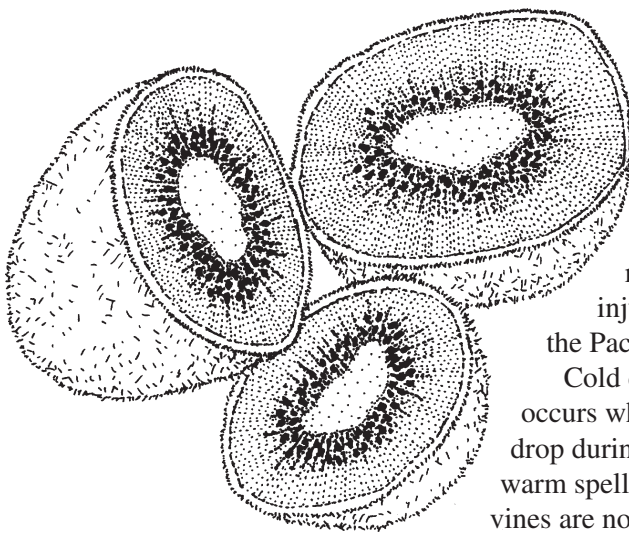

Hayward

Hayward is the most commonly available cultivar found in stores. Its large, fuzzy, brown fruit with good, sweet flavor has made it popular. This cultivar is recommended only for areas of Oregon and Washington with mild winters.

Harvest: mid- to late October, depending on summer heat units

Fruit weight: 80–90 grams

Vine growth: vigorous

Yield: up to 100 lb/vine

Saanichton 12

This cultivar comes from Vancouver Island, British Columbia, where it has been grown for more than 30 years. Fruit are large, somewhat more rectangular than Hayward, sweet, and of good flavor. The inner core of the fruit can be tough. It is reported to be more winter cold hardy than Hayward.

Harvest: early October

Fruit weight: 70–80 grams

Vine growth: vigorous

Blake

A “self-fertile” cultivar that does benefit from cross-pollination. Fruit are smaller than Hayward or Saanichton 12 and are more oval in shape. Flavor is inferior to Hayward and Saanichton 12.

Harvest: early October

Fruit weight: 60–70 grams

Vine growth: vigorous

Male (*A. deliciosa*)

A pollinizer is required for all fuzzy kiwi, with the possible exception of Blake. There are many cultivars/selections of males available. Examples include

Matua, Tomuri, Cal Chico No. 3, Chico Early, and Chico Extra Early. Males of these cultivars have not been tested for differences in performance in the Pacific Northwest.

Hardy Kiwi

The hardy kiwifruit species most recommended for production in the Pacific Northwest is *A. arguta*. In 2000, there were an estimated 100 acres of *A. arguta* cultivar Ananasnaya in the Pacific Northwest. Very few cultivars of this species are grown here.

Hardy kiwi plants are very vigorous and produce a good-quality, highly aromatic fruit that is quite different from the fruit of *A. deliciosa*. Fruit are smooth skinned (skin can be eaten), generally green in color, and much smaller than the fuzzy types. The flavor is excellent, but it varies by cultivar. Vitamin C content is very good at 10 to 70 mg per 100 grams of fresh fruit. Hardy kiwifruit are well suited to the home garden.

A. arguta is grown commercially in the United States, Canada, New Zealand, Chile, and parts of Europe. Oregon, with an estimated 100 acres of the cultivar Ananasnaya in production in 2000, is the world’s largest production region.

Commercial acreage has been limited mainly by marketing factors, such as development of fresh markets for this relatively unusual fruit, the range in fruit size, the limited ripening period, and the relatively short storage and shelf life compared to fuzzy kiwifruit. The continued

development of processed markets likely will strengthen this industry. As markets are developed, you will see and hear more about these types, as they do have good-quality, attractive fruit.

A. arguta is hardy to –10 to –25°F (–23 to –32°C) under most conditions. Damage to the trunk from cold temperatures rarely occurs in Oregon or Washington. Keep in mind that young vines may be more cold sensitive. Protect them with trunk wraps (see “Establishing Your Kiwifruit Vineyard”).

Maximum hardiness levels given for this species reflect only midwinter hardiness. This species has a low chilling requirement (winter rest period satisfied by temperatures at 32 to 45°F) and may be sensitive to cold injury at higher temperatures when warm weather precedes a cold spell, particularly in late winter.

Unfortunately, warm temperatures in February or March may promote early bud break, making this species very susceptible to frost damage of the young shoots. Therefore, this species cannot be grown commercially in most areas without frost protection when temperatures drop below 32°F after bud break (also see “Site selection”). In Oregon and most areas of Washington, frost protection is required in the late winter/early spring after bud break occurs. However, trial plants at Washington State University–Mt. Vernon have grown well without frost protection—probably due to the marine influence of the Puget Sound.

Production requirements for this crop are a well-drained soil

with a neutral pH, no history of phytophthora root rot or presence of nematodes, and a source of good irrigation water.

Fruit of hardy kiwi are best when ripened on the vine to maximize development of aroma and flavor; however, shelf life then is shortened. Harvest dates given below are based on sugar levels of 10 to 14 °Brix. (If left on the vine, the fruit will reach 18 to 25 °Brix.)

Ananasnaya

This is the most popular hardy kiwifruit cultivar currently available. Its Russian name means “pineapplelike.” You also may hear this cultivar referred to as “Anna.”

Fruit are of very good quality, with a good aroma and sweet, intense flavor. They have green skin that develops a purple-red blush in full sun, especially when vine ripened. Skin may be slightly tough.

The cultivar Ananasnaya brought to Oregon is *A. arguta*. However, the Russian Ananasnaya cultivar is *A. kolomikta*; more than one cultivar with the same name may be available in nurseries.

Harvest: mid- to late September

Yield: 60–150 lb/vine

Fruit weight: 6–14 grams

Vine growth: very vigorous

Issai (self-fertile)

This cultivar from Japan is less vigorous than the other hardy kiwifruit cultivars listed above. Fruit are smaller in size,

somewhat cylindrical, come to a point, and are fully green. Flavor and aroma are very good. Harvesting is somewhat more difficult than for the other hardy kiwi, because fruit are smaller and ripen rather unevenly within a cluster. This cultivar, although self-fertile, produces larger fruit with seeds when cross-pollinated. Vines are slightly less hardy than other *A. arguta* at 0 to –10°F (–18 to –23°C).

Harvest: early September

Yield: 50–90 lb/vine

Fruit weight: 4–9 grams

Vine growth: moderate vigor

74-49

This numbered selection came from a USDA program in Chico, California. This selection produces very good-quality fruit of similar size and quality to Ananasnaya.

Harvest: early to mid-September

Yield: 60–125 lb/vine

Fruit weight: 6–12 grams

Vine growth: very vigorous

Jumbo

Not yet widely tested in the Pacific Northwest. The green fruit are reputed to be of good flavor, larger than those of Ananasnaya and ripening in late September.

A. arguta* var. *cordifolia

Not yet widely tested in the Pacific Northwest. The green fruit have a good flavor and are very sweet. Plants are very vigorous and produce high yields. Flowers may be wind pollinated.

A. purpurea

A red-skinned, red-fleshed hardy kiwifruit. This species has not yet undergone extensive testing in the Pacific Northwest. Fruit generally are smaller than those of Ananasnaya and ripen in early October. Flavor is good.

Ken’s Red

Not widely tested in the Pacific Northwest, this kiwifruit from New Zealand is a cross of *A. arguta* var. *cordifolia* and *A. melanandra*. Fruit are nearly square to cylindrical with a “nib” at the tip. They are bright green in summer, and skin turns red late in the season. Flesh is reddish purple when ripe. Vines are very vigorous.

Male

Pollinizer for above *A. arguta* species. About one male is needed for every eight females. There is evidence that *A. arguta* cultivars can be pollinated by *A. deliciosa* males, which produce more pollen than *arguta* males. However, *A. deliciosa* males are much less hardy than *A. arguta* males; thus, you risk crop loss to cold injury when using fuzzy males (see “Pollination” for more information).

Other cultivars/selections that may be available include Dumbarton Oaks, 74-45, 74-8, and Michigan (reported to have almost twice the fruit size of Ananasnaya). These cultivars have not been widely tested in Oregon.

Kolomikta Kiwi

These kiwi types, *A. kolomikta*, are hardy to -40°F (-40°C), but shoots are sensitive to frost damage. In the Willamette Valley, Oregon, *A. kolomikta* cultivars have been found to break bud earlier than *arguta* types in late winter, making them more sensitive to frost. Available cultivars differ greatly in fruit shape, size, color, and flavor. Fruit of *kolomikta* are smaller than those of *arguta* kiwivines. Plants are considered good ornamentals because of their variegated pink leaves, particularly in the male.

The fruit are small to medium-size, but very sweet, with good aroma and flavor. Fruit are valued for their exceptionally high

vitamin C content—700 to 1,000 mg/100 grams of fruit (10 times higher than Hayward and 20 times higher than citrus).

Fruit are best when ripened on the vine to maximize aroma and flavor development; however, shelf life then is shortened.

This species has not performed well in test plantings at the NWREC, Aurora, Oregon, or in British Columbia, Canada.

A. kolomikta seems more sensitive than other species to wet soils or phytophthora root rot and does not grow well in full sun based on findings at the NWREC.

A. kolomikta is not grown commercially in the Pacific Northwest.

Nevertheless, the following cultivars may perform well at

other sites and certainly would make good ornamental fruit plants in the home garden.

Krupnoplalnaya

This cultivar, “large fruit” in Russian, is the largest of the arctic beauties tested in Oregon. Flavor is good and sweet. Plants have low to moderate vigor compared to *A. deliciosa*.

Pautske

This is the most vigorous of the arctic beauties tested in Oregon. Fruit are large and of good quality. Plants are more vigorous than those of *Krupnoplalnaya*, but still have lower vigor than *A. deliciosa*.

Male

An *A. kolomikta* male is needed to pollinize the above cultivars.

Establishing Your Kiwifruit Vineyard

Vine growth and fruiting habit of both fuzzy and hardy kiwifruit are similar. The following information on vineyard establishment applies to all of the aforementioned species unless differences are noted.

Site Selection and Preparation

Proper site selection, soil preparation, irrigation system design, planting design, and training are essential to developing a productive kiwifruit vineyard.

Site selection

The single most limiting factor for fuzzy kiwifruit production is temperature. *A. deliciosa* Hayward can withstand temperatures as low as 10°F (-12°C). Cold injury to Hayward has occurred in some winters in the Pacific Northwest.

Dormant *A. arguta* vines are much more cold-hardy than the fuzzy types (to -10 to -25°F or -23 to -32°C). However, young vines of this species also can suffer winter injury, particularly to the trunk, if temperatures fluctuate from warm to cold in late winter. Both *A. arguta* and *A. deliciosa* vines are sensitive to late winter or spring frost damage after bud break.

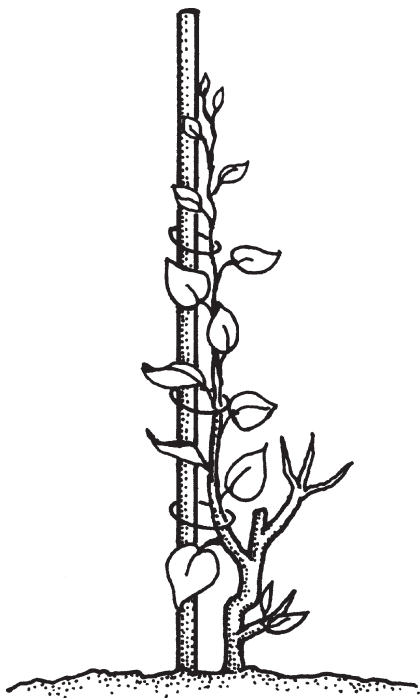

Male vines are less hardy than female vines (documented in Oregon).

There are several ways to help prevent freeze and frost injury:

- Do not plant in low areas or cool sites.
- Remove barriers (e.g., trees) to cold air drainage.
- Keep in mind that clean, cultivated sites are warmer during frost periods than sites with permanent cover crops.
- Do not cultivate immediately prior to a projected frost, because cultivation reduces heat transfer from soil to air at night.
- For protection from frost damage using irrigation after bud break, see “Irrigation.”
- Wind machines or heating devices such as smudge pots can prevent frost damage during temperature inversions (warm air is above the colder air).
- In the home garden, you can use spunbound row covers to offer some protection. Place covers over plants before sunset and remove when temperatures rise above freezing.

Chemicals that reduce vine transpiration (antidesiccants) have not been shown to reduce frost injury in kiwifruit.

Wind damage

Long shoots are very susceptible to wind damage or breakage in spring and summer. Not only can wind cause fruit loss, but it also may reduce economic yields by causing the fruit to rub. When rubbed, fuzzy kiwi first lose their fuzz and then develop a callus, whereas the hardy types develop a callused or scabbed area. Scabbed fruit are suitable only for processing.

In windy areas, wind breaks such as poplars help reduce economic losses. Plant wind breaks to provide 200 to 250 feet of protection downwind. Make sure wind breaks are not planted close enough to the vineyard rows to reduce yield of the kiwifruit through competition for light and water.

Soil

The optimum pH for Hayward is between 5.5 and 6.0. Vines show poor growth at a pH above 7.2. It is not known whether other species differ in pH requirements. However, *A. arguta* has performed well in Oregon at the same pH range.

Kiwivines do best in deep, well-drained soils. They are very sensitive to standing water, especially after bud break in spring. Research in New Zealand has shown that if roots are waterlogged for 3 days or more, the root system and vine growth are severely damaged.

In California, it is recommended that kiwifruit be planted on 3 feet of well-drained soil. However, Hayward vines have grown well on soils with an

Table 1.—Guidelines for irrigation water quality.

Chloride	< 70 ppm
Bicarbonate	< 200 ppm
Boron	< 0.25 ppm
Sodium	< 50 ppm
Electrical conductivity, EC x 10	< 0.75

effective rooting depth of 2 feet, provided the water table is lower than 2 feet.

Install well-designed drain tiles to improve drainage if necessary. Ripping the soil below the row before planting also can benefit growth.

In the Pacific Northwest, we recommend planting vines on raised beds (at least 1 foot high). This method reduces risk of vine death from phytophthora root rot. Young and mature vines of *A. deliciosa* and *A. arguta* have been killed by phytophthora when grown on “flat ground” in Oregon.

Do not pile soil around the base of the trunk of established kiwifruit vines with the objective of forming a “raised bed” after planting. Doing so can kill vines.

Previous cropping history

Kiwifruit are susceptible to verticillium wilt. Avoid planting in soils with a history of strawberry, black raspberry, potatoes, or other crops in the Solanaceae family.

Plants also are sensitive to root knot nematodes (*Meloidogyne* spp.). Although the literature on nematodes relates to Hayward, it's best to assume that *A. arguta* is similarly sensitive. Kiwifruit also are susceptible to Armillaria oak root fungus, which may be present on sites where oak trees have grown.

A preplant soil test for nematodes is recommended. If nematodes or oak root fungus are present, use a preplant fumigant.

Young kiwifruit vines compete poorly with weeds, so eliminate as many perennial weeds as possible before planting. A permanent cover crop or a natural weed strip may be maintained between rows.

Water

A plentiful supply of good-quality water is required for kiwifruit production. Plants need 40 to 48 acre-inches of water per year. Expect to apply about 2 inches of water for each inch of water needed. Table 1 shows guidelines for irrigation water quality that are considered safe in California.

Vineyard Planning, Planting, and Spacing

We estimate that it costs more than \$12,000 per acre, not including land cost, to establish a kiwifruit vineyard and bring it to production. It takes 3 or more years after planting to produce a commercial crop.

Planting design

Presently, the common training system used for kiwifruit vineyards in the Pacific Northwest is a

pergola (solid overhead canopy). However, a T-bar system has yielded well at the NWREC, is easier to prune, and may be better suited for small-scale production.

For a T-bar trellis, vines commonly are planted 15 feet apart in rows 15 feet apart, resulting in 194 plants per acre. With a ratio of 1 male: 8 females, there are 174 female vines per acre. For the pergola, you may want to space rows 15 to 20 feet apart (see “Trellis”).

Kiwifruit vines are extremely vigorous. Canes grow 6 to 12 feet per year, and occasionally 20 feet. Higher density plantings may increase production in the early years, but in later years, overgrowth and shading will require excessive summer pruning.

The kiwifruit is a dioecious plant—it has separate male and female plants (with the exception of a few self-fertile cultivars). Male vines are essential for pollination and crop production. In general, plant the same species of male as the female vines (see “Pollination”) and about one male for every eight female plants. Male and female vines must be present in a block and must flower at the same time.

You can achieve a 1:8 male–female ratio with the following design:

- Plant only female plants in all outside rows.
- Plant the following row with a male plant between every two female plants.
- Plant the next two rows with all female plants.

- Plant another row with a male plant between every two females.
- Plant two more rows of all female plants.
- Continue as above.

Male plants in these planting systems run at right angles to the rows. For T-bar systems, you may want to place males in every row, as there is some evidence that bees prefer to work down rows rather than across.

Planting

Self-rooted vines perform better than grafted vines in the Northwest’s cold winters. Although grafted kiwifruit are available from many nurseries, planting kiwifruit on their own roots in areas where cold injury may occur is recommended. Severe cold spells can kill a grafted vine past the graft union, thus killing the vine. On cold-injured, self-rooted vines, suckers can be trained up from below the winter-killed portion.

Using rootstocks in kiwifruit production could offer many advantages:

- Vigor reduction
- Greater tolerance for adverse soil conditions such as water logging
- Greater physiological cold tolerance
- Resistance to pests or diseases
- More precocious and higher-yielding vines

However, research is needed on rootstock possibilities in kiwifruit.

Plant 2-year-old bare-root or container stock. Purchase

bare-root nursery stock as close to planting time as possible. Don’t allow the roots to dry out. Plant as early in the spring as possible. Container-grown plants can be planted at any time except mid-summer.

Plant on raised beds to reduce the risk of phytophthora. Carefully mark your field prior to planting. Planting all of the males first and then filling in with females is recommended.

Install your irrigation system before planting (see “Irrigation”). Establish your trellis prior to, or just after, planting (see “Trellis”). Place the row posts between plants so that if post repair is needed, the vine trunk will not be in the way.

Make the planting hole large enough to accommodate the roots without bending them. You may trim the roots a little to make them fit the hole. Do not dig the hole deeper than needed. Do not add any fertilizers, including manures, to the planting hole, as the roots are very sensitive to fertilizer burn. Incorporate soil amendments the fall prior to planting.

Plant vines just deeply enough to cover the top roots. Never mound soil around the plant, even when the plant is established. Keep the soil moist enough to promote root growth, but don’t overwater, which can cause anaerobic conditions that promote root rots.

You can paint the trunks with a mixture of 1:1 water and interior white latex paint to help prevent sunburn. Milk cartons also can protect against sunburn and rodent feeding. Place a trunk wrap

around all species of kiwifruit vines in winter, except for *A. arguta* older than 5 years. “Grow tubes” can be used on young plants throughout the growing season. However, in warmer areas damage has occurred to the young trunk where the top of the grow tube ends.

Trellis

Kiwifruit vines are not self-supporting; their size, vigor, longevity, and heavy crop load mean they need a strong, permanent support structure.

Two main types of support structures or trellises are used in commercial kiwifruit production: the T-bar and the pergola. A pergola provides a single plane of canopy about 6 feet above the ground. The T-bar trellis system consists of posts in rows with a cross arm at 6 feet high.

T-bars are less expensive to construct, less labor-intensive to manage, and better suited to bee pollination. However, pergolas may produce more yield per acre, and the fruit are less susceptible to wind damage. Also, once the full canopy is established in a pergola, the shade reduces weed growth.

T-bar

A typical T-bar trellis consists of posts with a 5- to 6-foot-long cross arm (depending on row width) extending across each post (Figure 1-A). The kiwifruit canes are tied to wires on top of the cross arm.

Use pressure-treated 4- to 6-inch diameter posts that are 8 to 9 feet long spaced at 15 to 20 feet down the row. Square posts are

easier to work with. Drive posts 2 to 3 feet into the ground. Use end posts that are at least 6 inches in diameter, and drive them at an angle with the top of the post leaning 1 foot from perpendicular away from the row. Anchor the end posts well.

The top of the cross arm is 6 feet above the ground. Cross arms usually are a 2 x 6 inch board bolted into a cut notch on the post. You can brace cross arms back to the post for added strength.

Run a wire down the row from the top middle and each side of

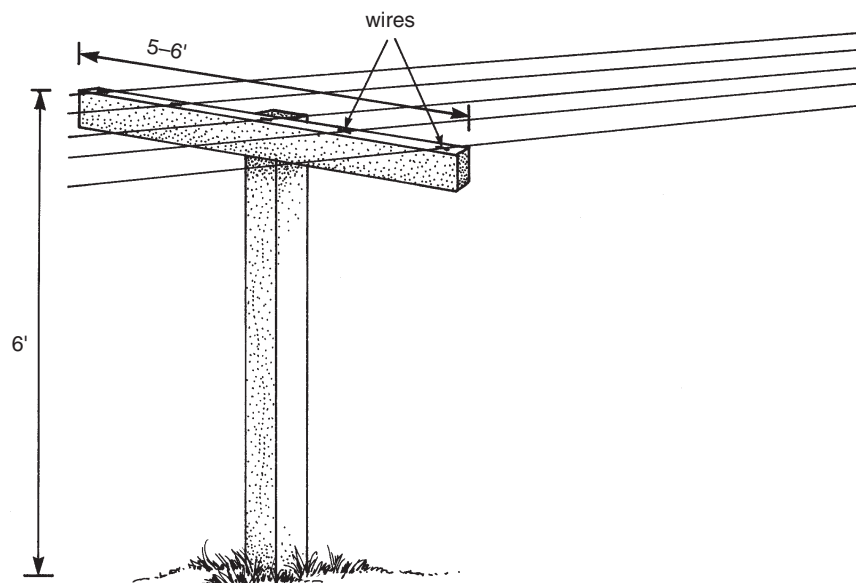

Figure 1-A.—Standard T-bar trellis system for kiwifruit.

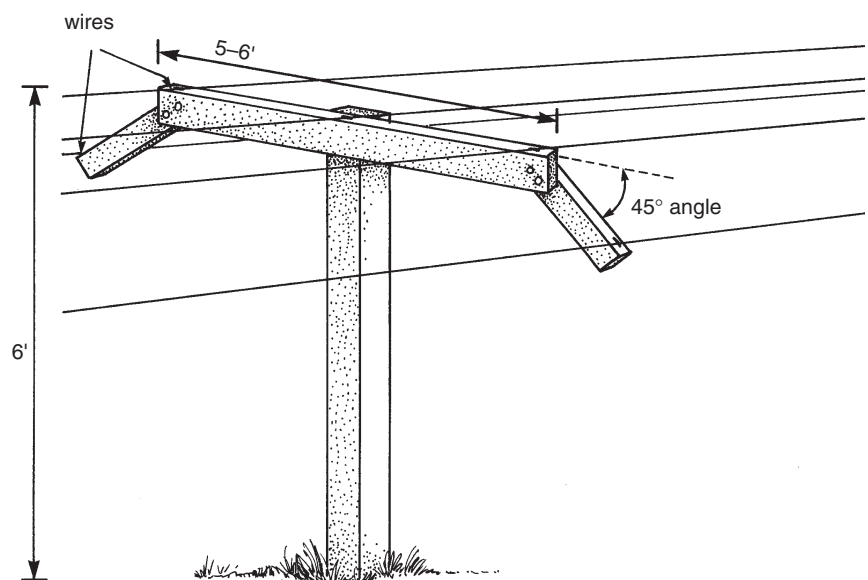

Figure 1-B.—Winged T-bar trellis system for kiwifruit.

the cross arms (Figure 1-A). Two additional wires can be added, one between the center and each end wire. Use galvanized, high-tensile, 12-gauge wire for the vine supports. Good wire tighteners are needed to keep a strong tension on the wires to support the vines and crop.

A common modification of the T-bar is the winged T-bar, in which an additional wing and wire are added to each side of the T-bar cross arm (Figure 1-B). Tying down a cane from the center wire onto the two wires pulls it into a more natural curve.

Pergola

A pergola trellis is designed to support a solid canopy of foliage and fruit (Figure 2). Wires not only extend down the row, but also are used as “cross arms” (more commonly than using wood) running perpendicular to the vine rows. The wires are placed 1 to 3 feet apart.

Irrigation

Good irrigation is critical for good growth and production. Irrigate young plants enough to wet the root zone without keeping the crown too wet; otherwise, crown or root rot may occur. In young plants, the range between too wet and too dry is narrow.

Unfortunately, there is relatively little direct experience on water requirements of hardy kiwifruit in the Pacific Northwest. The following information relates to Hayward production and our observations with *A. arguta* here in the Pacific Northwest.

Growers often irrigate by experience rather than irrigation scheduling tools. In kiwifruit, however, observing vines for trouble signs doesn't work well, because by the time water stress symptoms are visible, damage has occurred.

Vines under mild or moderate water stress have a subtle off-color

look, with the foliage turning blue-green. Other symptoms include poor shoot growth, wilting, small fruit, sunburn, and reduced yield in the current and following season. In situations of severe water stress, vine leaves will turn yellow.

There are various types of irrigation systems. Unfortunately, there is no single best system. Design a system that can supply up to 35 gallons of water per mature vine per day during the growing season. Irrigate vines once or twice per week. Surface mulch may help conserve soil moisture.

Drip systems

Drip systems economize on water use, but on lighter soils often supply water to only a narrow cone of soil. Frequent irrigations are necessary, particularly to young plants with small root systems. However, as the crown tends to stay drier, risk of crown rot (phytophthora) may be reduced. You can't use drip systems for frost protection.

Drip irrigation systems commonly are used in California in young plantings. At planting, one emitter is placed near each plant. The second year, two emitters are placed 12 to 18 inches from the trunk, and the one near the trunk is removed (to keep the trunk relatively dry). When the plant is 4 years old, two more emitters are added 3 feet away from the trunk.

When plants are mature, California growers find it difficult to supply enough water with four emitters per vine, so they add more emitters or switch to minisprinklers. For larger vines, as

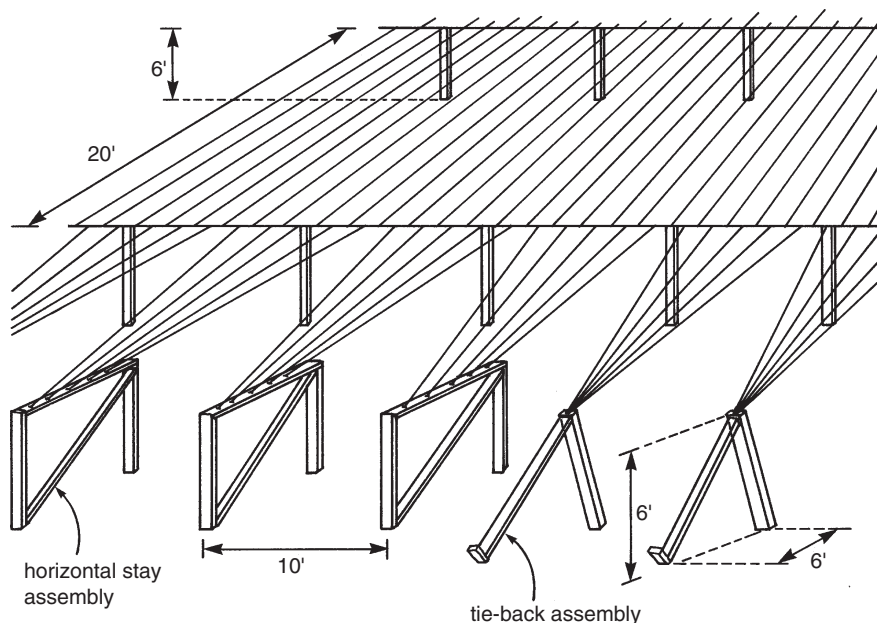

Figure 2.—Pergola trellis system for kiwifruit.

many as 10 emitters per vine may be necessary.

Minisprinkler systems

Under-vine minisprinkler systems, which produce a wetted area of greater size, often are preferred over drip systems. In general, they wet more soil than drip emitters do, are easy to install, and tend to plug less frequently than drip emitters. They can be used to replace drip systems as vineyards age. In young vineyards, however, minisprinklers tend to overirrigate.

These sprinklers spray water in a 6- to 18-foot diameter circle. One full-turn minisprinkler per vine, located equidistant between vines, should be adequate in mature plantings. Generally, they are run 6 to 12 hours, two to four times per week.

Impact sprinklers

Impact sprinklers are the most common type of irrigation system used in kiwifruit vineyards in the Pacific Northwest. They can be placed over or under the canopy. Impact systems work well if the canopies aren't in the way, but they tend to use more water than drip or minisprinkler systems.

Overhead sprinklers are best for frost protection. Some growers use a T assembly on the sprinkler riser to switch from over-vine sprinklers to under-vine sprinklers. They use the over-vine positions for frost protection (shoots in the spring, fruit in the fall) and switch to the under-vine position in summer. (Note that only fuzzy kiwifruit are sensitive

to fall frosts, because hardy kiwifruit mature earlier.)

Place under-vine sprinklers between vines in order to reduce impact on the trunk.

Frost protection

All kiwifruit species are sensitive to frost damage in the Pacific Northwest. After chilling is satisfied and temperatures warm up in late winter or spring, buds will break. Only one shoot is produced per node. If that shoot is damaged by frost, no crop will be produced at that node. We have observed total crop loss after bud break at temperatures below 32°F without frost protection.

Over-canopy sprinklers can provide 6 to 8°F frost protection, whereas under-vine impact sprinklers can provide about 2 to 3°F protection. Typically, $\frac{5}{16}$ -inch sprinklers are used at a spacing of 30 x 40 feet (at 50 lb/inch pressure) to supply 0.1 inch/hour (50 gallons/acre/minute). Start sprinkler irrigation before temperatures fall below the critical level (31 to 32°F), and continue until temperatures are above critical levels and ice melts.

Fertilization

It is relatively easy to burn the roots of kiwivines, so apply fertilizer cautiously. The following recommendations are based on our experiences in the Pacific Northwest.

Fertilize young kiwifruit vines monthly with small amounts of nitrogen (N). Ammonium nitrate and urea are good sources of nitrogen for kiwifruit.

In the first year, apply no more than 0.4 oz of actual N per plant per month in May, June, and July (12 lb actual N per acre for 160 plants per acre). Spread the nitrogen in a circle 6 to 12 inches from the base of the trunk.

In the year after planting, apply 0.8 oz of N per plant per month in April, May, June, and July (32 lb N per acre). Spread the fertilizer in a ring about 12 to 36 inches from the trunk.

Fertilize third- and fourth-year plants with 2 to 3 oz of actual N every other month from March through July (60 to 90 lb N per acre). Apply the fertilizer as a broadcast band under the vine canopy. You may liquid-feed nitrogen to young plants on a 2-week to monthly interval instead of using granular fertilizer.

Do not fertilize young plants with liquid or granular forms of nitrogen later than July. Late fertilization forces late vegetative growth, which is very sensitive to cold injury. Once plants bear fruit, the crop load tends to suppress late vegetative growth and reduce the risk of fall frost damage.

Other nutrients may be added in spring either foliarly or to the soil surface. Base applications on nutrient needs/analysis. Kiwifruit vines tend to take up a considerable amount of phosphorus (P) and potassium (K). Test soil for P and K prior to planting, and incorporate nutrients preplant if necessary.

DO NOT use fertilizer containing chloride (i.e., KCl), as kiwivines are very sensitive to chloride.

Training Young Vines

Proper pruning during the establishment years is necessary to establish a well-formed permanent framework for the vine. Developing or training young kiwifruit vines into a bilateral cordon allows for easier management when the plants are mature. Kiwifruit produce a crop on shoots that grow from 1-year-old canes (last year's growth). In the first few years, you train vines the same way for both the pergola and the T-bar system.

Prune dormant kiwivines in late December to late January in the Pacific Northwest. Later pruning may cause excessive sap flow.

First growing season

The main objective during the planting year is to develop a single, straight trunk. At planting, prune plants back to one or two buds (above the graft union in grafted plants) (Figure 3-A, page 14).

Once shoots start to grow, select one vigorous shoot to train upward as the trunk. Place a stake beside the shoot to facilitate training. String from the wire to the stake can add support as well. Tie the shoot to the stake (not too tightly or you'll girdle the shoot) at frequent intervals to help prevent breakage (Figure 3-B).

Do not allow the shoot to wrap around the stake. Concentrate growth into this shoot by removing suckers at the base of the vine.

Remove all basal lateral shoots that break along the trunk. If the main shoot loses vigor and begins

to twist slightly, top the shoot and train up the strong new "leader" (Figure 3-C). Continue to train the trunk until it's 2 to 3 inches above the wire (Figure 3-D).

If the shoot reaches the wire early in the season, you may try to form the cordons in the first year. To do so, top the shoot to about 4 inches below the training wire to encourage lateral branch formation. This forms a nice "Y" for the cordons. Select two shoots, growing in opposite directions, and train them along the center wire to form the two main arms, called cordons (Figure 3-E).

Another option is to train the trunk up one way along the wire and wait until the next season to train a shoot the other way. This results in cordons of unequal age, which may make management a little more difficult in the short-term.

During the first dormant season, head back the cordon(s) to wood of 1/4 inch in diameter or larger (Figure 3-E). If vines did not have adequate growth to form cordons the first season, head the trunk back about 2 inches below the trellis wire to force new buds early the next season.

Second season

The objective in this season is to develop two permanent cordons from two strong shoots growing in opposite directions from the trunk along the center wire. If cordons were established in the planting year, there will be a light crop produced in year two. As each cordon grows, lay the shoot atop the wire and tie it every 18 to 24 inches with tie tape to ensure

that it's securely attached to the wire. If only a trunk was established in the planting year, train two shoots near the top of the trunk, just under the wire, to become the cordons. Remove all other shoots and any suckers throughout the season.

Retain shoots that are produced along the cordons at about 8- to 12-inch intervals. Carefully tie these shoots to the outer trellis wires. Remove all other shoots by summer pruning before they twist around the shoots you want to keep. Remove unwanted suckers and shoots throughout the season.

In the dormant season, prune the main cordons and the retained lateral canes back to wood 1/4 inch in diameter or larger (Figure 3-F). A crop will form on shoots from these canes in the third year. Pruning the canes during the dormant season encourages fruiting the following year.

Third season

Continue to extend the cordons, if necessary, by training the strongest shoots down the center wire until they're within about 1 foot of the cordon of adjacent vines. Do not allow them to twist tightly around the wire, which might restrict sap flow later.

Continue to train lateral branches perpendicular to the cordons (Figure 4, page 15). Do not train shoots along the outer wires parallel to the cordon; they would cause too much competition for light.

In the third dormant period, prune so that 15 to 20 well-spaced lateral canes remain on the vine, depending on vigor. Fruit will

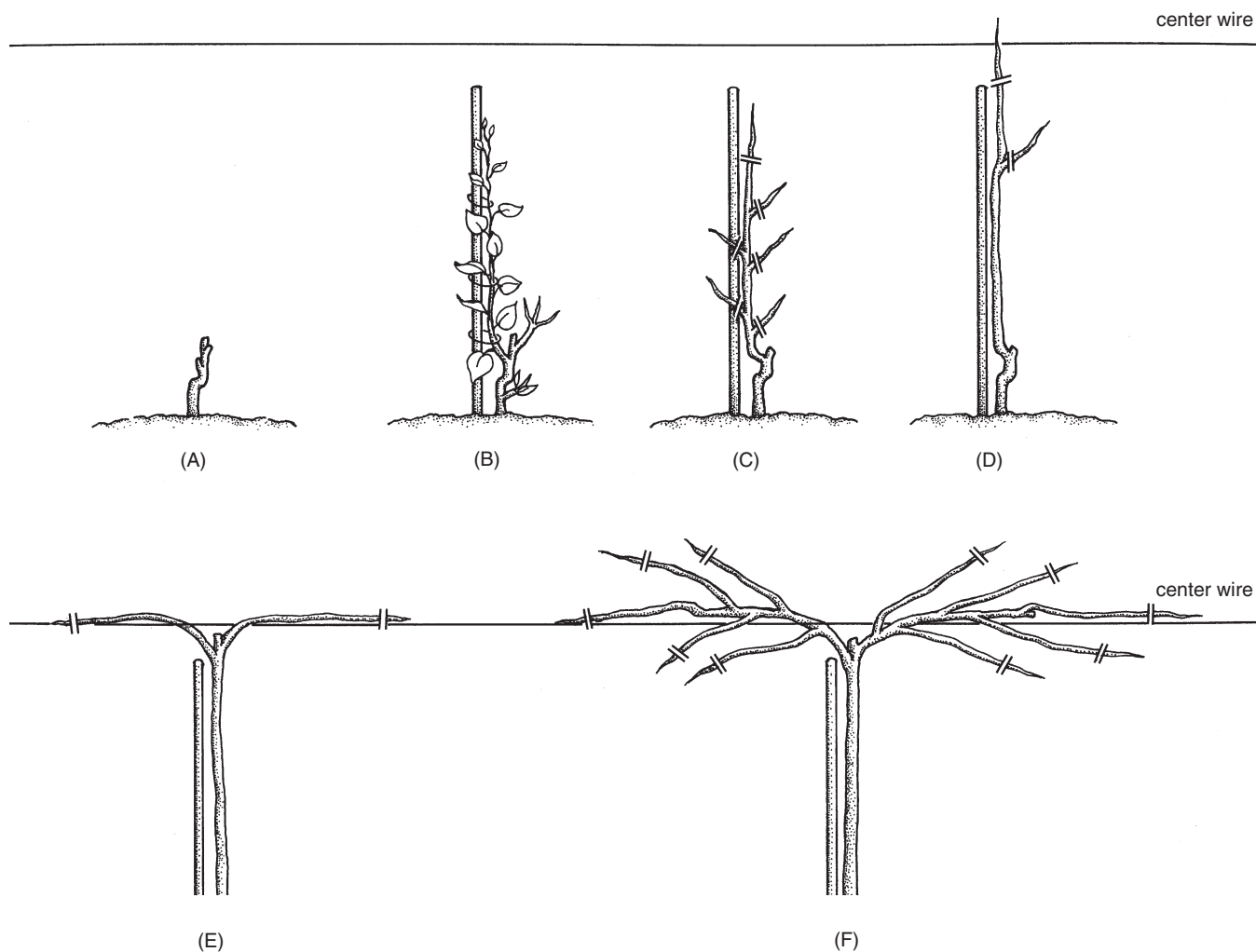



Figure 3.—Training a young kiwifruit vine. Pruning cuts are shown by .

(A) Prune to one or two buds at planting.

(B) Train one shoot as trunk; remove all others (Year 1).

(C) Head back trunk as shoot growth at terminal loses vigor.

(D) Continue to remove lateral shoots; let trunk grow beyond wire. Then head to just below wire.

(E) Choose two shoots to form cordons, one each way on wire. Head back to $\frac{1}{4}$ -inch-diameter wood in dormant season (Year 1).

(F) Shows shoot growth Year 2. Pruning cuts in dormant season Year 2 are shown.

form on shoots produced on last year's growth (Figure 4). Do not overcrop (allow a young vine to produce too much fruit).

Overcropping will lead to high yield, but small fruit size, reduced vegetative growth, and a reduced crop the following year. Reduce crop by leaving fewer buds or 1-year-old fruiting canes. Remove any suckers or side growth on the trunk. Concentrate on developing or finishing the vine's framework. Fruit in the third year may sunburn due to inadequate canopy

cover. It may be a good idea to remove some of the fruit early in the season to divert more energy into vegetative growth.

The permanent vine structure should be established by the third or fourth year. Future pruning will renew fruiting canes and maintain the vine framework and crop load. See "Maintaining Your Kiwifruit Vineyard" for diagrams/descriptions of pruning mature vines.

Training of vines to a T-bar and pergola system is similar. In a pergola, the vines are grown as

straight, single trunks until they reach the top of the structure. One strong permanent leader (cordon) then is allowed to grow in each direction along the main wire.

To form the canopy of a pergola, develop a system of fruiting canes from the cordons at right angles to the wires. Fruiting canes can be retained longer on pergolas and may be more permanent than on T-bars. Fruiting laterals or shoots develop on the fruiting canes. It takes up to 7 years to develop a full canopy in a pergola.

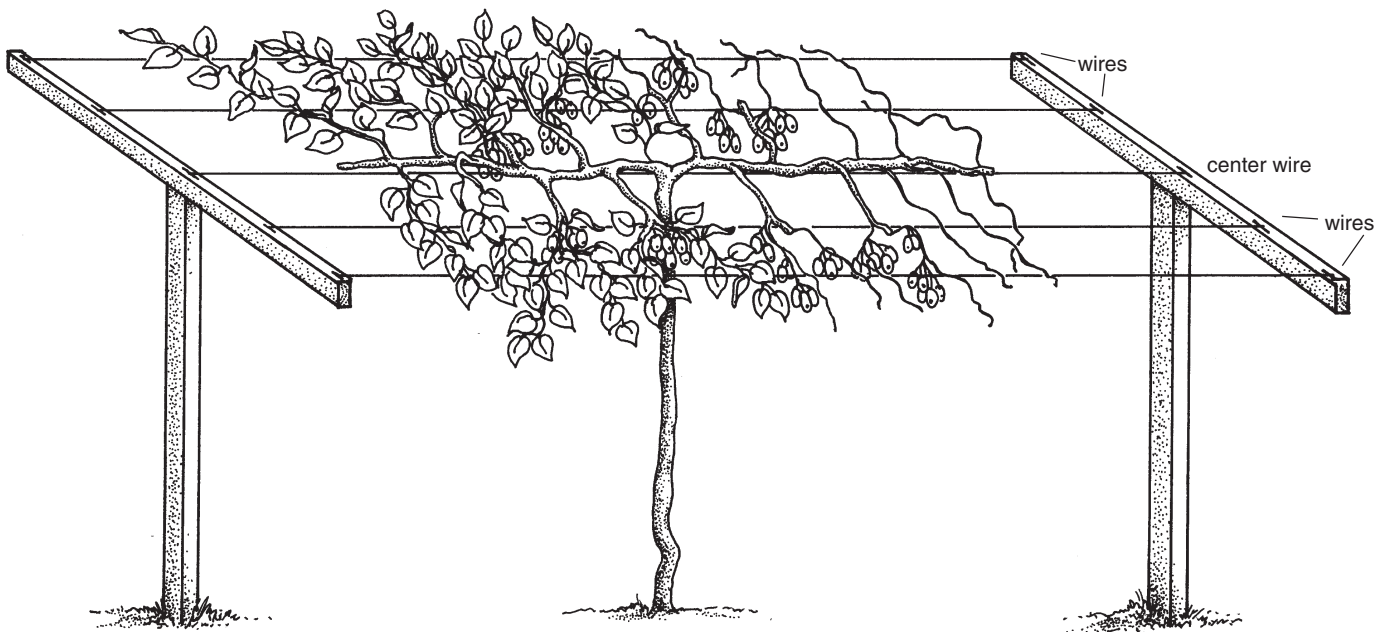

Figure 4.—Kiwifruit vine in third growing season during fruiting. Leaves not shown on right to simplify drawing.

Maintaining Your Kiwifruit Vineyard

It is essential to maintain your kiwifruit vineyard well for optimum growth and productivity. Pruning probably is the most challenging aspect of vineyard maintenance.

At Oregon State University, we have conducted several experiments on the fruiting and pruning of hardy kiwifruit. Our findings are incorporated into this chapter.

Fertilization

It is relatively easy to burn the roots of kiwivines, so apply fertilizer cautiously. When applying granular N, be sure to broadcast it over the entire root zone area; concentrating it near the trunk can burn roots. Leaf necrosis or blackening of the leaf edges is a symptom of fertilizer burn.

Mature vines (7 years and older) use about 1 lb of actual nitrogen per vine per year, or about 190 lb N per acre per year (with 15 x 15 foot spacing).

Apply about two-thirds of the nitrogen in March at bud break as a broadcast application under the canopy. This provides the nitrogen needed for early-season growth and fruit set in June. A second application of granular N, the remaining one-third, is recommended in May–June.

Plants should have good soil moisture when they are fertilized. Irrigate first, wait 1 or 2 days, then fertilize; or fertilize after a good rainfall.

You can substitute liquid fertilizer applied through the irrigation system for dry fertilizer. When applying liquid fertilizers containing N, use about 10 lb of actual N in each application from April through July. Higher rates of liquid N (20 lb per application) have injured roots on lighter soils.

Base fertilization with other nutrients on tissue and soil analysis. Critical levels for leaf samples taken in late August in California and for New Zealand are given in Table 2 (recommendations from

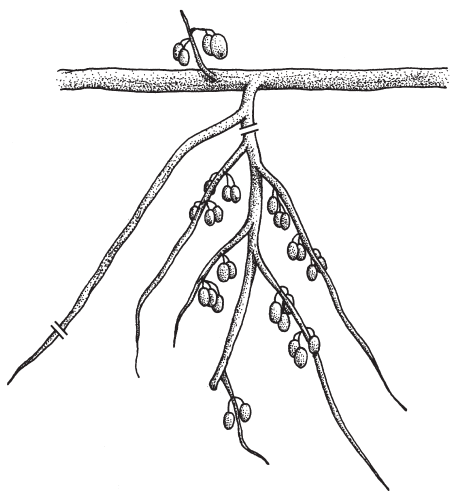

Table 2.—Kiwifruit leaf sufficiency levels for nutrients.

Nutrient	% dry weight	Nutrient	ppm
Calcium	2.0–4.0	Boron	25–200
Magnesium	0.2–0.8	Copper	5–15
Nitrogen	2.0–2.8	Iron	60–200
Phosphorus	0.13–0.3	Manganese	50–200
Potassium	1.5–2.5	Zinc	15–30
Sulfur	0.15–0.45		

both areas are combined). It is not known whether species differ in nutrient needs or whether critical levels vary by region. However, these values can be used as a guide.

Based on experience in New Zealand and California, growers typically apply the following as a maintenance application:

- 55 lb phosphorus per acre in February–March
- 80 to 130 lb potassium per acre as a single application in late winter/early spring or split, depending on soil type

Maintain soil pH at about 6.0 with lime application in the fall.

Kiwifruit are very sensitive to chlorine, so do not use any fertilizers with chloride.

Irrigation

The water a vine loses through transpiration must be replaced by irrigation or rainfall. Transpiration occurs when leaves use carbon dioxide to produce carbohydrates through photosynthesis. On a warm summer day in California, mature, full-canopy kiwifruit vines can transpire 7,000 to 8,000 gallons of water per acre per day.

Irrigation is necessary to keep vines growing and productive and to maximize fruit size. Water stress can reduce fruit size, limit flower numbers (by reducing flower bud initiation), and cause premature fruit drop. Summer drought can cause leaf drop and premature fruit ripening in *A. arguta*; however, fruit ripen

more unevenly and are of poorer flavor. Severe drought also may cause fall flowering, which reduces the following year's production. Maturity of wood also seems to be delayed by drought, thus increasing risk of cold injury. However, too much water also may cause production problems.

Judging vine water needs is difficult. At this time, it's not known whether irrigation requirements in the Pacific Northwest differ from those in other regions. Based on information from British Columbia, Canada, vine water use ranges from 25 to 35 gallons per vine per day (at 70 to 80°F).

Irrigation for frost protection also is necessary to protect young shoots in spring and potentially fruit in fall (for fuzzy kiwifruit only). See "Establishing Your Kiwifruit Vineyard" for more information.

Pollination

For fruit to be produced, male and female vines must be present in a block and must flower at the same time. Male flowers produce viable pollen for only the first 2 to 3 days after opening. However, female flowers are receptive to pollen for 7 to 9 days after opening, even when the petals have started falling.

Pollination is extremely important in kiwifruit production. Large Hayward fruit contain 1,000 to 1,400 seeds, and Ananasnaya fruit contain up to 240 seeds. If pollination is poor, fruit will have indentations (narrow valleys) on

one side or be nonuniform in shape. If you cut through these fruit, you'll find no seeds in these areas.

Hardy kiwifruit vines, even when well pruned, can have 10,000 flowers per vine.

Kiwifruit flowers are pollinated mainly by insects, although wind may play a minor role. Honeybees are the main pollinator used in kiwifruit vineyards.

Kiwifruit flowers do not produce nectar and are relatively unattractive to bees. About three to four hives per acre are needed to adequately pollinate kiwifruit. Place hives in the vineyard no sooner than 10 percent bloom of the *female* vines.

In some years, you may have no male vines in flower as a result of cold injury to male plants in late winter or early spring (they are less hardy than the females). In this case, no naturally produced pollen will be available. To get a crop, the females will have to be pollinated artificially. There are presently no sources of *A. arguta* pollen. Fortunately, *A. deliciosa* pollen will work well for *A. arguta* females. Pollen is sent in a pure form with about 20 million pollen grains per gram. To provide artificial pollination, you must apply 10 grams per acre per day starting at about 10 percent bloom of the female vines. You can apply pollen with a special "dry" applicator or in a solution. Call your county Extension faculty for more information on sources of pollen and methods of artificial pollination.

Fruit Thinning

Fruit thinning, or removing fruit after set, can be done to remove misshapen fruit that are unmarketable and to increase the size of the remaining fruit. However, after studying fruit thinning in hardy kiwifruit, it is doubtful whether thinning is economical. Proper dormant-season pruning balances the crop load and can greatly affect fruit size. Leaving too many buds after pruning will decrease fruit size.

Pruning and Training

Proper pruning is necessary for several reasons:

- To establish and maintain a well-formed permanent framework for the vine
- To obtain a balance between vegetative growth and fruit production
- To develop a canopy that uses available light efficiently (for photosynthesis), yet is open enough to obtain maximum fruit quality and flower bud formation for next year's crop. An open canopy also facilitates harvest and reduces the risk of fungal diseases such as botrytis
- To maintain consistent yield and fruit size

All species of kiwifruit can be pruned in a similar manner. However, there are many different ways to prune a kiwivine. The following description covers the basic techniques.

Dormant pruning

Dormant pruning of kiwivines is best done in late December to late January in the Pacific Northwest. Late-pruned vines may have excessive sap flow, which may weaken vines.

In kiwifruit, flowers are produced on current-season shoots that grow from buds developed on 1-year-old canes (last year's growth). Shoots that grow from older wood seldom produce fruit in their first season. Shoots from buds that were heavily shaded during the preceding season are

less productive than those from buds that were exposed to the sun. That's why it's important to prune well so that the canopy is open and well exposed to light. Research at Oregon State University has shown that hardy kiwifruit start initiating flowers for next year's crop in July and that shading reduces the number of flowers formed.

Our research has shown that in *A. arguta*, all 1-year-old canes and spurs are equally productive per foot of length and produce a similar fruit size, regardless of

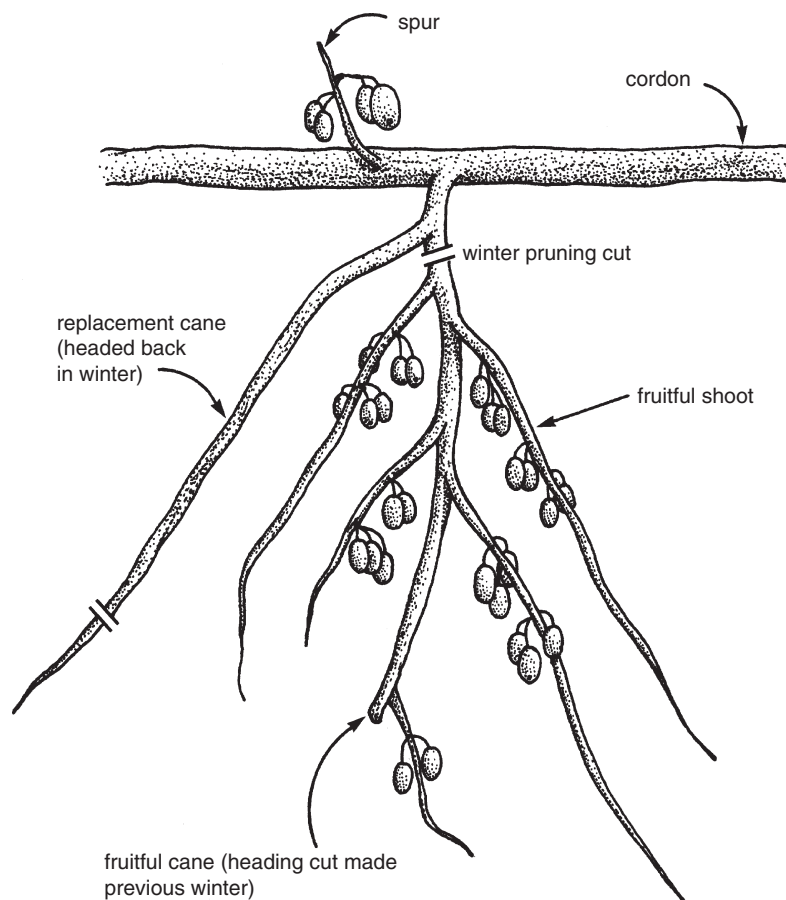

Figure 5.—Mature portion of a kiwifruit cordon in production. Leaves are not drawn to simplify the figure. Fruit are produced on shoots growing from last year's growth. Winter pruning cuts are shown by **==**.

where they originated (cordon, 2-, or 3-year-old wood). That's why it's easy to prune a kiwifruit too lightly, leaving too many fruiting buds. The most productive part of long 1-year-old canes is from nodes 6 to 40. The buds at the base of canes usually produce only a vegetative shoot (no flowers). The fruitful buds produce shoots that bear flowers from nodes 6 to 12.

When mature, male and female plants should be pruned differently.

Female vines. When pruning a mature vine, remove about 70 percent of the wood that grew last season. Most of the wood removed is older wood that already has fruited. New fruiting canes usually will have developed at the base of last year's canes. Figure 5 shows a typical fruiting cane that developed from the permanent cordon.

Replacement fruiting canes that originate from the cordon may be left to replace older wood in the future. Fruiting canes should be separated by about 8 to 12 inches on the cordon. Head back replacement fruiting canes to force growth next season, and tie them to the wires for support. Do not tie canes too tightly or they'll girdle during the growing season.

Spurs (shorter fruiting branches with short internodes) often originate from the older wood. Do not remove them unless necessary, as they also are fruitful (Figure 5).

Remove most of the older wood back nearly to the cordon. When necessary, you can leave some 2-year-old wood with its 1-year-old wood attached for fruiting wood if 18 to 48 inches of new

growth is present beyond where fruit was formed last season (Figure 6). Head back these fruiting laterals to 2 to 4 buds in fuzzy kiwifruit and to 8 to 12 buds in hardy kiwifruit beyond where fruit was formed last year. Often you can see where the fruit was borne last year because the old fruit stems (pedicels) do not fall

off the vine. The area of the cane that bore fruit last year (normally nodes 6 to 12 in hardy kiwifruit) will not have buds present and thus will not produce any shoots. Expect from 25 to 57 percent bud break (typically about 50 percent).

Take care that 1-, 2-, and sometimes 3-year-old fruiting canes are distributed evenly on the

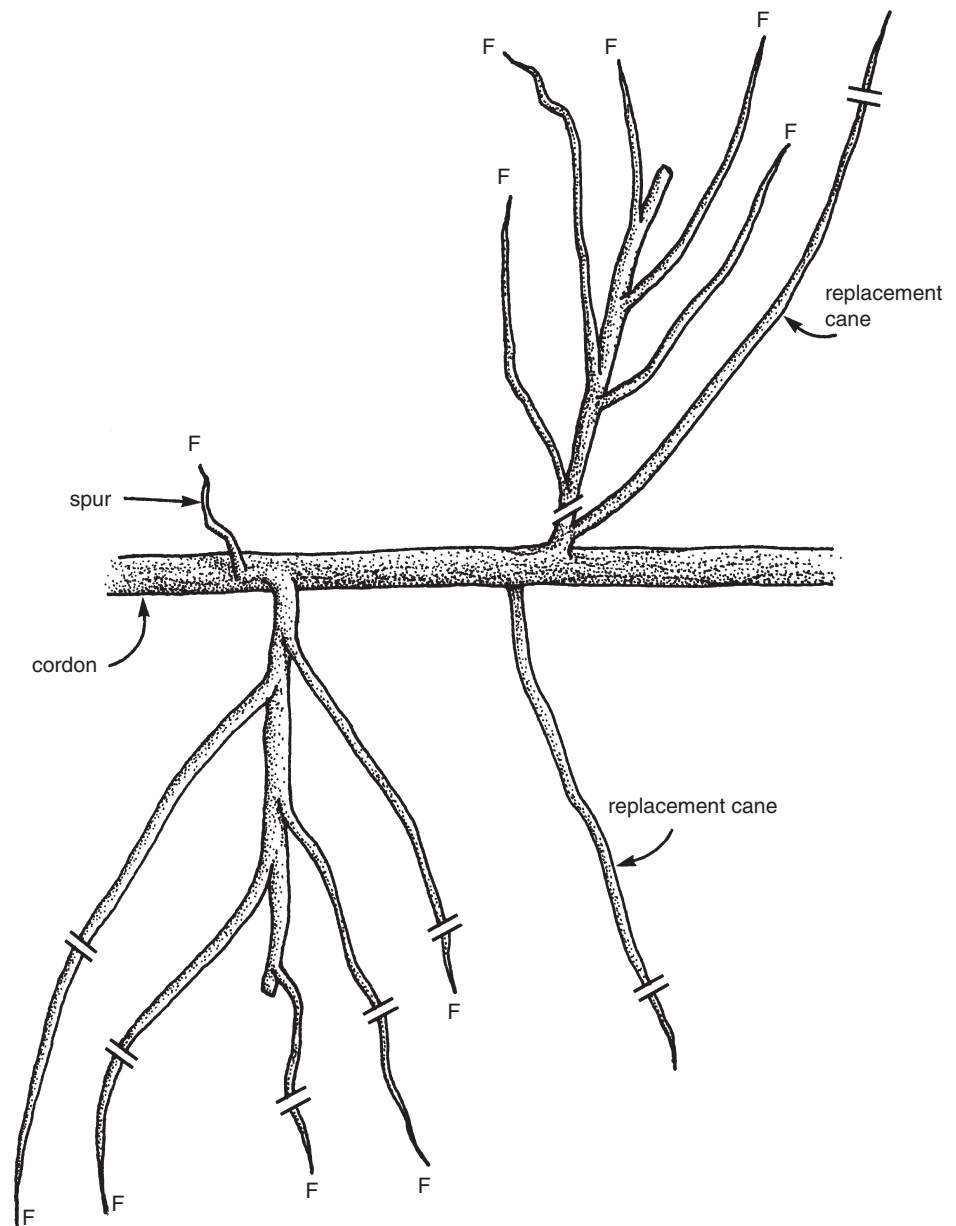

Figure 6.—Dormant portion of a mature kiwifruit vine cordon. Winter pruning cuts are shown by \equiv . Shoots labeled with an "F" fruited last season.

trellis to avoid overcrowding in any area of the canopy.

Remove twisted and tangled growth, shoots that cross from one side of the vine to the other, and wind- or cold-damaged shoots. Mature vines, spaced at 15 feet in the row, should have 30 to 45 fruiting canes per vine (spaced at 8 to 12 inches on both sides).

Male vines. The goal when pruning male vines is to produce as many flowers as possible for pollination, while keeping the vine manageable. It is best to prune male vines only lightly in the dormant season—just enough to remove tangled shoots and keep vines manageable. After flowering (late June), prune male vines, using the same principles as

discussed for the female vines.

In hardy kiwifruit we have found that the cordons of female and male vines need to be replaced every 3 to 4 years. To replace the cordon, lay a vigorous vegetative shoot down along the center training wire in each direction. Do this the year before you plan to remove the old cordon. The following season, lateral shoots will be formed along the new cordon; space these as discussed in “Establishing Your Kiwifruit Vineyard.” Once a good replacement cordon and fruiting canes are established, cut off the old, unproductive one.

Summer pruning

In the Pacific Northwest, growers generally have done little

summer pruning other than to remove unwanted suckers from the base of the vine and hedging. Hedging is done only in the T-bar system to keep the aisles open. Use a sickle bar to cut shoots back to about 2 feet from the edge of the trellis. Some thinning (removal) of excessive vegetative shoots not needed for next year also can be done. Take care not to prune excessively in the summer, as fruit and sometimes canes may become sunburned.

Some shoots in hardy kiwifruit will naturally stop growing. Early in the growing season, after bloom, the tip of some shoots will die, leaving a dead, black tip approximately 6 inches long. This is natural and does not indicate the presence of a disease.

Harvest, Handling, and Storage of Kiwifruit

Most of the research on harvest, handling, and storage of kiwifruit has been done with the most common kiwifruit grown commercially, Hayward (*A. deliciosa*). Therefore, most of the information presented here for hardy kiwifruit is based on grower experience or observation rather than on research findings.

Fruit Maturation

Kiwifruit continue to increase in fresh weight and size until harvested, but the most rapid size increase occurs the first 100 days after bloom in Hayward and 60 days in Ananasnaya. Kiwifruit are one of the few fruits that retain a high starch content at maturity.

Starch hydrolysis, or breakdown, continues after harvest, even at 32°F, and is essentially complete within a few weeks after

harvest. Freshly harvested kiwifruit can be cleared of starch in 4 to 6 days if held at 68 to 77°F (20 to 25°C) in an ethylene environment.

A decline in starch content as fruit mature is coupled with an increase in percent soluble solids

(sugars). The increase in soluble sugars that begins as kiwifruit approach maturity continues after harvest and peaks about the time that starch hydrolysis is complete. As fruit mature on the plant, part of the increase in sugars occurs as the plant produces more carbohydrate through photosynthesis.

With advancing maturity, the accumulation of carbohydrate slows, yet the sugar content continues to increase. At this time, the increase in sugars primarily is due to the conversion of stored carbohydrates (mainly starch) to sugars. Kiwifruit contain lots of glucose and fructose and a small amount of sucrose.

At the peak of carbohydrate accumulation, fruit have essentially achieved their best potential eating quality, and further delays in harvest will not improve flavor.

Fruit size within a vine is not related to fruit maturity. Also, most cultivars show little visual change in fruit appearance as they mature. For these reasons, it is unreasonable to attempt multiple harvests from a vine. Hayward tends to have more uniform ripening of fruit within a vine than do the arguta cultivars (Ananasnaya, for example).

Soluble solids (sugar) content (°Brix) is the most commonly used maturity index for kiwifruit. In California, Hayward are

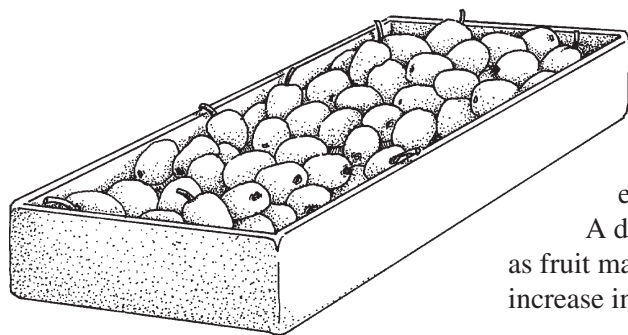

harvested at a 6.5 percent soluble solids standard (6.5 °Brix). Fruit then will attain good quality in storage. In Oregon, Hayward fruit do not reach 6.5 °Brix until the end of October to early November. Soluble solids content is about 12 to 18 percent when ripe.

In the *arguta* cultivars, fruit are at about 18 to 25 percent soluble solids when ripe. However, to increase shelf life and facilitate harvest, this species of kiwifruit is harvested between 8 and 14 °Brix when fruit are still firm—usually in early to mid-September in Oregon. Vine-ripened fruit (October) become very soft, and the stem pulls from the fruit leaving a wound; these fruit cannot be stored.

The soluble solids content of kiwifruit can be measured with a hand-held refractometer. Cut a wedge extending from the stem to blossom end of the fruit and squeeze the juice from the fruit.

Starch in unripe kiwifruit will cloud the solution and make refractometer readings difficult. Pour the sample through a few layers of facial tissue to clear the solution. For a non-temperature-corrected refractometer, follow the directions for accurate °Brix readings carefully.

A sample of kiwifruit can be ripened fairly easily to monitor ripe fruit soluble solids content, but this takes several days. To ripen small samples, place fruit with fresh apples (to provide a source of ethylene) in a slightly vented plastic bag. At 77°F (25°C), ripening takes 4 to 5 days.

Harvesting

Once the minimum maturity standards have been achieved, all of the fruit can be harvested in one picking. Harvest fruit by hand. To harvest fuzzy kiwifruit, pickers should wear soft cotton gloves to prevent damage to the skin (fuzz) of the fruit. Fruit are easily damaged by rough handling even though they seem quite hard at this stage of maturity.

When *arguta* fruit are too ripe or soft when picked, fruit will tear at the stem end. This is not a problem when harvesting at 8 to 14 °Brix and fruit are hard. Riper fruit are delicious, but their shelf life is very poor. Enjoy them immediately or keep separate from other fruit.

Pickers should use gloves or clip their nails short to avoid damaging the skin of hardy kiwifruit. Pick hardy kiwifruit without the stem. Break the stem at the fruit–stem juncture, by hand.

Keep fruit in the shade while awaiting transport, and cool them as quickly as possible to maximize storage life. Field heat must be removed quickly from fruit after harvest, because the fruit can lose water quickly. After 3 to 4 percent water loss, fruit may appear shriveled, especially at the stem end. This is less of a problem with *A. deliciosa* in the Pacific Northwest (compared to California), because fruit are harvested in October–November.

Softening of kiwifruit also is temperature-dependent. Fruit at 41°F (5°C) soften three times faster than fruit at 32°F (0°C). Avoid exposing fruit to ethylene, a gas that promotes ripening and fruit softening.

Fruit usually are sorted for size and quality before packing. If fruit are not packed immediately, store them in large bins.

Storage

Store kiwifruit as near to 32°F (0°C) as possible at 90 to 95 percent relative humidity with ethylene gas scrubbers to maintain an ethylene-free atmosphere. Even when fruit are held at this temperature, about one-third to one-half of the remaining flesh firmness may be lost per month of storage (Hayward). Fruit are sensitive to freezing injury; be careful that the temperature of the fruit does not drop below 32°F.

For long-term storage, use of controlled atmosphere (5 percent CO₂, 2 percent O₂) has been effective for Hayward, provided temperature is kept at 32°F and an ethylene-free atmosphere is maintained. Note that only battery-operated forklifts should be used in storage rooms to avoid generating ethylene. Monitor levels of ethylene in storage on a regular basis, because a week or more of 10 ppb ethylene will hasten fruit softening.

Hayward fruit can be stored 3 to 6 months under ideal storage conditions. Hardy kiwifruit, however, can be stored less than 2 months, because fruit are more perishable.

Before shipping, fruit can be exposed to ethylene to trigger the ripening process. Although fuzzy kiwifruit are sold loose, unwrapped, hardy kiwifruit are best sold in clamshell packages that maintain a higher humidity (to prevent shriveling) and prevent fruit damage.

Pests

Although a few pests are reported to be of concern in kiwifruit (see “Site Selection”), the only pests that have been observed to cause problems in hardy kiwifruit vineyards in Oregon are phytophthora root rot and some secondary insect pests, which

move in from adjacent orchards. Fruit rot (botrytis) has been observed in cases of less-than-ideal or longer-than-recommended storage conditions. No disease or insect pest has been found associated with the shoot tip die-back that is observed in the summer (see “Summer pruning”) or with fruit scarring.

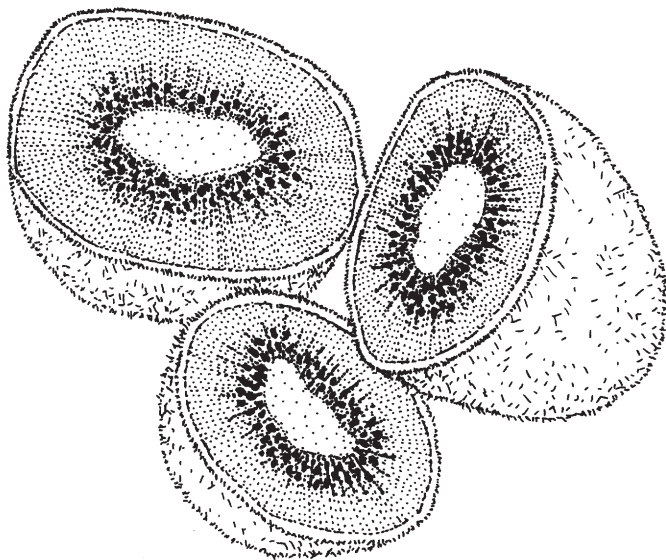

For more information

Many Extension Service publications may be viewed or downloaded from the Web:

Oregon State University—<http://extension.oregonstate.edu/>

University of Idaho—<http://info.ag.uidaho.edu/>

Washington State University—<http://pubs.wsu.edu/>

© 2004 Oregon State University

Pacific Northwest Extension publications are jointly produced by the three Pacific Northwest Land-Grant universities: Oregon State University, Washington, State University, and the University of Idaho. Similar crops, climate, and topography create a natural geographic unit that crosses state lines. Since 1949, the PNW program has published more than 550 titles, preventing duplication of effort, broadening the availability of faculty specialists, and substantially reducing costs for the participating states.

Published and distributed in furtherance of the Acts of Congress of May 8 and June 30, 1914, by the Oregon State University Extension Service, Washington State University Extension, University of Idaho Cooperative Extension System, and the U.S. Department of Agriculture cooperating.

The three participating Extension Services offer educational programs, activities, and materials—*without regard to race, color, religion, sex, sexual orientation, national origin, age, marital status, disability, and disabled veteran or Vietnam-era veteran status*—as required by Title VI of the Civil Rights Act of 1964, Title IX of the Education Amendments of 1972, and Section 504 of the Rehabilitation Act of 1973. The Oregon State University Extension Service, Washington State University Extension, and University of Idaho Extension are Equal Opportunity Employers. Published February 1998. Revised April 2004.

\$3.50